

MFLOW

PL Carbon & PL Carbon Pro

User Manual

2025.06







This document is copyrighted by AMFLOW with all rights reserved. Unless otherwise authorized by AMFLOW, you are not eligible to use or allow others to use the document or any part of the document by reproducing, transferring, or selling the document. Users should only refer to this document and the content thereof as instructions to operate AMFLOW products. The document should not be used for other purposes.

Using this Manual

Legend

 Important

 Hints and Tips

 Reference

Read Before Use

AMFLOW™ provides users with tutorial videos and the following documents:

1. *Safety Guidelines*
2. *Quick Start Guide*
3. *User Manual*

It is recommended to watch all tutorial videos and read the *safety guidelines* first, then assemble and set up the product by reviewing the *quick start guide*. Refer to this *user manual* for more information.

Important Information

This manual contains important information about safety, assembly, and maintenance. Please read the whole manual carefully before using for the first time.

- Refer to the manufacturer's instructions and official website to learn the usage and service information of the third-party components on the electric bicycles (hereinafter referred to as bikes).
- Assembling, fixing, and maintaining the bike requires professional skills and specialty tools. This manual only contains basic operations and precautions. It is recommended to have authorized retailers carry out the assembly, troubleshooting, and maintenance if you cannot operate by yourself.

- Refer to the warranty document provided with your bike or visit <https://www.amflowbikes.com/support/policy> for the warranty information about this product.
 - The bikes have a fixed pre-set speed limit at which the motor assistance will automatically shut off.
 - Do not make any unauthorized modifications to the drive unit. Otherwise, the warranty may become void.
 - This manual is subject to update. Please check the latest version from <https://www.amflowbikes.com/pl-carbon/downloads>.
 - Ensure electrical connectors remain clean and dry. Do not apply any grease or adhesives to the connectors. Avoid exposure to humid or dusty environments to prevent short circuits. Ensure connections are securely fastened when installing the electrical components.
- * While riding, the A-weighted sound pressure level is less than 70 dB(A).

Contents

Using this Manual	2
Legend	2
Read Before Use	2
Important Information	2
1 Product Profile	6
1.1 Overview	6
1.2 Intended Use	7
2 Riding Safety	8
2.1 Riding Precautions	8
2.2 After an Impact	8
3 Assembly	10
3.1 Specifications	10
Component Specifications	10
Bolt Specifications	10
3.2 Cable Routing	12
Cabling Overview	12
Drive Unit	13
Control Display	13
3.3 Headset	14
3.4 Stem and Handlebar	15
3.5 Seatpost	16
Seatpost Insertion Requirement	16
Adjusting the Seatpost	16
3.6 Wheels	18
Adjusting Rear Wheel Size	18
Speed Sensor Ring	18
3.7 UDH Hanger	19
3.8 Chainring	20
Chain Guide	21
3.9 Drive Unit	22
Drive Unit Guard	24
3.10 Control Display	24
Installing the nano-SIM Card	25
3.11 Wireless Controller	27
Replacing Battery of Controller	27
Replacing the Controller	27
3.12 Battery	28

3.13	Speed Sensor	29
3.14	Bike Light and Reflectors	30
4	Riding Tips	31
4.1	Before Your First Ride	31
4.2	Before Every Ride	32
4.3	Preparation for Riding	32
4.4	Drive System	32
	Download Avinox App	32
	Pair and Activate	33
	Button Features	33
	Assist Mode	34
	Standard Mode	34
	Boost Mode	34
	Walk Mode	35
5	Maintenance	36
5.1	Bike Maintenance	36
	Cleaning	36
	Lubrication	37
5.2	Regular Inspection	37
5.3	Replacing Wearable Components	38
	Bearing and Spacer Specifications	39
	Replacing the Cables	40
	Cable Guide	40
	Rear Brake Cable	41
	Rear Derailleur Cable	41
	Seatpost Cable	41
	Drive Unit to Display Cable	42
5.4	Link Maintenance	42
5.5	Battery Maintenance	43
5.6	Storage and Transportation	44
	Storage	44
	Transportation	44

1 Product Profile

1.1 Overview



- | | |
|------------------------|--------------------|
| 1. Brake Lever | 7. Shift Lever |
| 2. Wireless Controller | 8. Top Tube |
| 3. Seatpost Lever | 9. Rear Shock |
| 4. Handlebar | 10. Seat Tube |
| 5. Stem | 11. Seatpost clamp |
| 6. Control Display | 12. Saddle |

- | | |
|---------------------|----------------------|
| 13. Seatpost | 24. Crank |
| 14. Yoke | 25. Chain Guide |
| 15. Shock Link | 26. Drive Unit |
| 16. Seatstay | 27. Internal Battery |
| 17. Brake Caliper | 28. Down Tube |
| 18. Rear Derailleur | 29. Head Tube |
| 19. Cassette | 30. Fork |
| 20. Brake Rotor | 31. Spoke |
| 21. Chainstay | 32. Rim |
| 22. Chain | 33. Tire |
| 23. Chainring | |

1.2 Intended Use

This bike is intended for condition 1, 2, 3, and 4. Below is the description of different conditions.

 This bike is not intended for use in condition 5. Failure to follow the intended use may cause damage to the frame and other components or even injury.

Condition	Description	Jumping Limitation
Condition 1	Flat and smooth paved surfaces, where the tires are always on the ground during riding.	Not Supported
Condition 2	Including condition 1, plus unpaved gravel roads and trails with moderate grades, where the tires can occasionally lift off the ground while riding.	<15 cm
Condition 3	Including condition 1 and 2, as well as rough roads and paths that require technical skills.	<60 cm
Condition 4	Including condition 1, 2, and 3, plus rough technical areas that require advanced technical skills, and moderately sized obstacles. Small jumps is supported during riding.	<120 cm
Condition 5	Including condition 1 to 4, as well as professional tracks and rugged terrains that requires extreme jumping maneuvers.	Unlimited

2 Riding Safety

After setting up the bike, make sure to read the Safety Guidelines and this manual to understand the safety notices and follow the instructions to perform all the safety check. Make sure you are completely familiar with the product functions before riding.

2.1 Riding Precautions

- Electric bikes accelerate much faster than regular bikes, make sure to pay particular attention to terrain conditions during riding, especially when there are obstacles on the road.
- Do not apply excessive brake force to the front wheel suddenly, as this could lift the rear wheel off the ground and result in a fall.
- During riding, pay attention to the road hazards such as potholes, road shoulders, drains, or objects that may damage the wheels.
- Make sure to shift gears correctly. Press the shift lever and then pedal forward to shift the derailleur.
- Do not move the bike backwards when the chain is on the larger cassette. Otherwise, the transmission may be damaged.
- Be careful to keep your body away from the sharp teeth of chainrings, the moving chain and the spinning wheels.
- The brake rotors and the motors may become hot during use. Do not touch.

2.2 After an Impact

If you accidentally fall off or sustain an impact during riding, ensure your own safety first. Before continuing to ride, check your bike condition as follows:

1. Check the whole bike if there are any deformation, damage or cracks. If any issues are detected, do not continue riding the bike. Take it to an authorized retailer for a thorough inspection.
2. If you hear any unusual noise, check if the bolts, bearings, and any other connecting parts are loose.
3. Check the battery: If the battery charging port is damaged or the battery is no longer securely fixed in the down tube, do not continue to use.
4. Check if there are any error messages displayed on the control display. Follow the instruction to troubleshoot before continuing to use.

5. Check if the wheels are securely attached to the frame and whether the rims are centered with respect to the frame or fork.
6. Check if the handlebar and stem are bent or damaged and whether the stem is firmly fixed.
7. Check if the handlebar and saddle are centered. If necessary, realign and re-tighten the bolts.
8. Check whether the transmission still functions normally. If any issues are detected, do not continue to operate the transmission and perform necessary maintenance and repair.

3 Assembly

Make sure that the components are assembled in accordance with the instructions before using. Consult the authorized retailer or professional bike shop if you encounter any problems that cannot be resolved by yourself during assembly.



This symbol means that grease should be applied as illustrated.



This symbol means that threadlocker should be applied to the threads as illustrated.



- Make sure to power off the drive system before assembling or disassembling.
 - Before riding, make sure that all the components are assembled and adjusted according to the manufacturer's instructions and are functioning properly.
 - Certain components and hardware parts on the bike are dedicated to AMFLOW. Make sure to only use genuine components for assembly. Otherwise, the bike may be damaged. Contact the authorized retailer or official customer service to purchase the genuine components if necessary.
-

3.1 Specifications

Component Specifications

It is supported to change the transmission, seatpost, wheels, rear shock, fork, and brake to other models. Before modification, ensure to consult the authorized retailer and component manufacturer about the compatibility.

Visit the following website for specifications:

<https://www.amflowbikes.com/pl-carbon/specs>



- Make sure to select the models that are compatible with the frame if you are changing the shocks. Use incompatible shock may cause damage to the frame and result in loss of control.
 - The speed sensor ring needs to be mounted on the replaced rear brake rotor and only supports to mount on a 6-bolt disc rotor.
-

Bolt Specifications

The following is a summary of the specifications of the bolts on the frame. Make sure to regularly check the torque of each bolt to ensure attachment of the components.

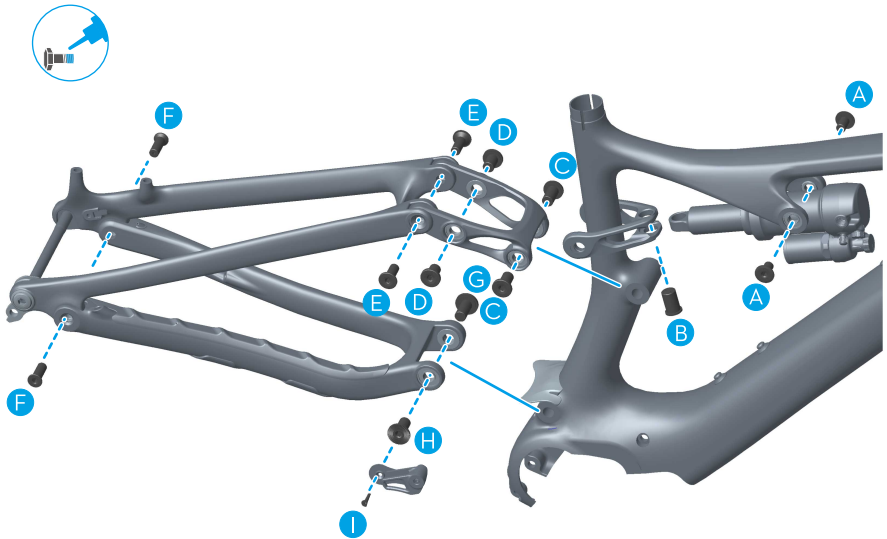

	Location	Quantity	Tools	Torque/N·m
A	Shock forward mounting bolts	2	H5	15
B	Shock rear mounting bolt	1	H8	20
C	Seat tube pivot bolts	2	H6	20
D	Yoke at shock link bolts	2	H6	24
E	Seatstay pivot bolts	2	H5	20
F	Swingarm pivot bolts	2	H5	15
G	Main pivot bolt-left	1	H6	24
H	Main pivot bolt-right	1	H6	24
I	Chain guide mounting plate bolt	1	H2.5	2



- Before mounting, ensure that all contact surfaces are clean and apply threadlocker to the threads.
- Ensure that each bolt is torqued to specification during mounting. Too much torque may cause deformation of the fastener, while insufficient torque may lead to loosening.
- Refer to the manufacturer's manuals for the bolt specifications of the third-party components if necessary.

3.2 Cable Routing

- 💡 • Make sure to route the cables through the frame before assembly.
- It is recommended to reserve a certain length of the rear brake cable and rear derailleur cable for potential extensions.

Cabling Overview

Place the cables into the corresponding positions of the cable guide and outlets as shown in the illustration:

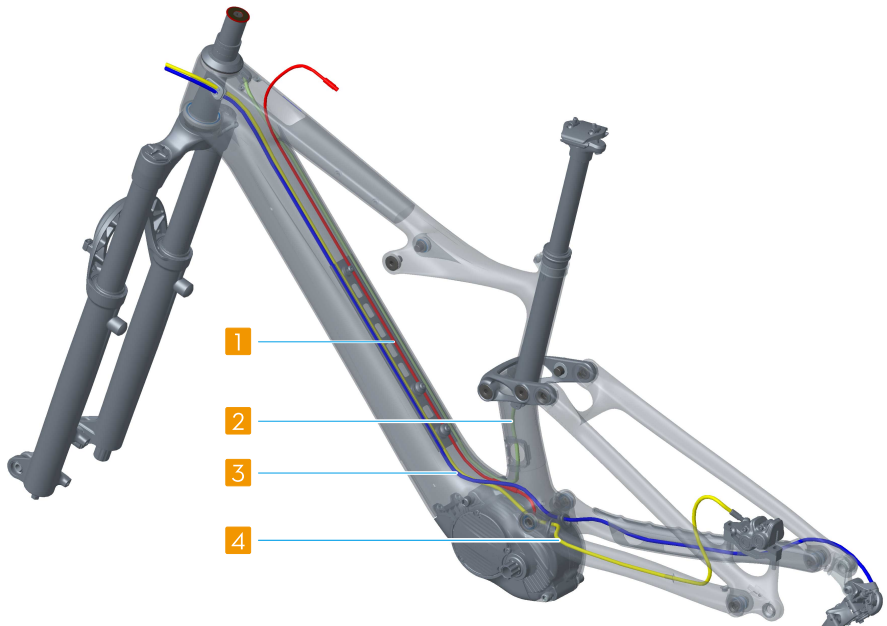

1. Drive Unit to Display Cable
2. Seatpost Cable
3. Rear Derailleur Cable
4. Rear Brake Cable

Drive Unit

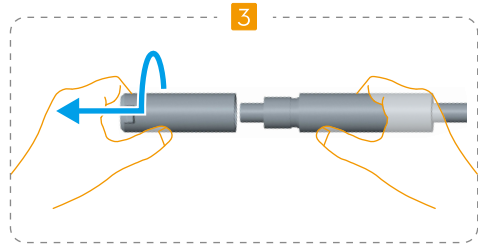
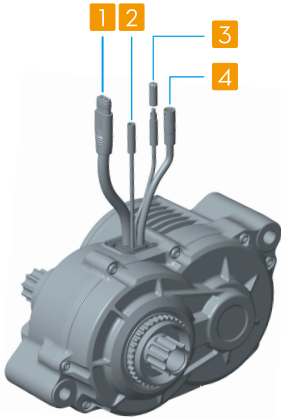

1. Power Cable Port
2. Speed Sensor Port
3. Expansion Port
4. Drive Unit to Display Cable Port



If you need to use the expansion port, make sure to pinch the end of the plug as shown in the illustration, then pull it out while rotating it to remove. Otherwise, the port may be damaged.

Control Display



1. Expansion Port
2. Drive Unit to Display Cable Port

3.3 Headset

The composition of the headset and stem is shown in the illustration. If replacement is needed, ensure that the replacement components are compatible with the genuine headset specification.

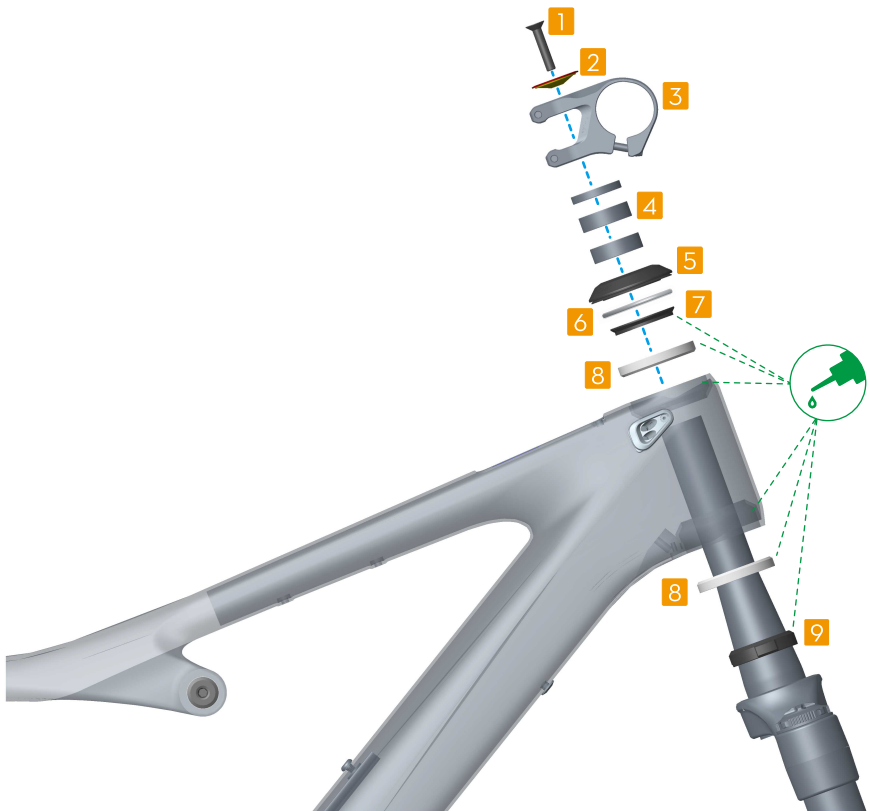

- | | |
|------------------|---------------------|
| 1. Stem Cap Bolt | 5. Top Cover |
| 2. Stem Cap | 6. Top Cover Seal |
| 3. Stem | 7. Compression Ring |
| 4. Stem Washer | 8. Headset Bearing |

9. Crown Race

-  A specialty tool is required to mount the crown race ⑨ onto the fork steerer tube. Please have an authorized retailer perform this operation.

3.4 Stem and Handlebar

Follow the steps below to assemble or disassemble the handlebar.

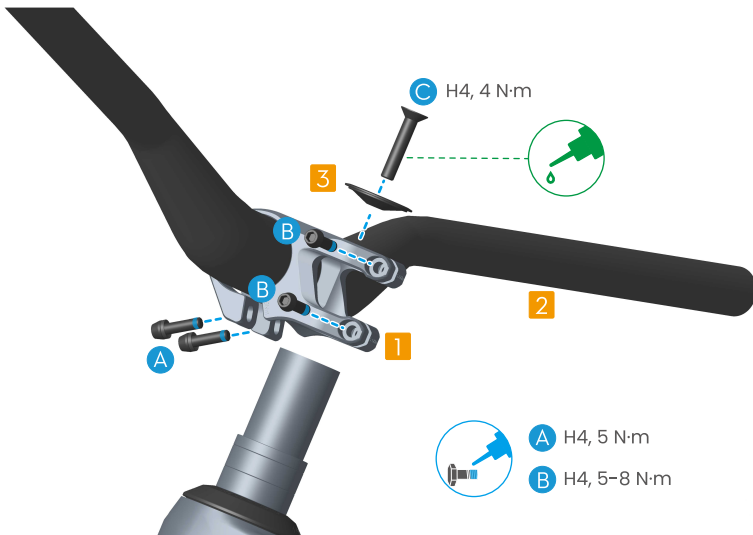

1. Attach the handlebar ② into the stem ①. Rotate the handlebar to the desired position, and tighten the bolts (A) to the specified torque. Then install the stem and handlebar to the head tube.
2. Place the stem cap ③ on the stem and tighten the stem cap bolt (C) to the specified torque.
3. Hold the front wheel and twist the handlebar until the stem is lined up with the wheel. Then tighten the stem bolts (B) to the specified torque.

3.5 Seatpost

Seatpost Insertion Requirement

Both the frame and seatpost have the insertion requirements. Failure to follow the requirements may result in damage to the frame and seatpost.

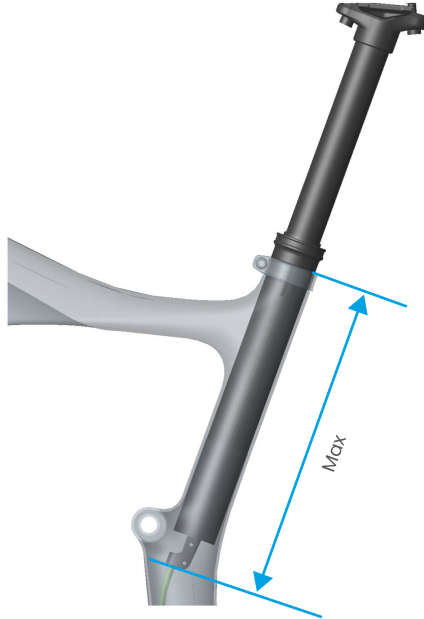

Frame Size	M	L	XL	XXL
Maximum Insertion/mm	250	270	290	320

- ⚠ • The seatpost should be inserted into the frame deep enough so that the minimum insertion mark on the seatpost is invisible.
- If the seatpost is inserted too much, the frame and seatpost cable may be damaged, causing the seatpost to malfunction.

Adjusting the Seatpost

Follow the steps below to adjust the seatpost.



1. Loosen the seatpost clamp bolt (A) and then loosen the cable guide bolts (B) and (C) by 2 to 3 turns.
2. After inserting a length of the seatpost cable into the down tube, lift the seatpost up carefully to prevent the cable from being detached.
3. When the adjustment is complete, tighten the seatpost clamp bolt (A) and then the cable guide bolts to the specified torque.

-
- ⚠** • Refer to the [Cable Guide](#) section to learn more about how to remove the cable guide.
- If the desired height cannot be achieved within the minimum and maximum insertion requirements, the seatpost should be replaced with one of a different length.
 - After adjustment, twist the handlebar side to side to check whether the length of the seatpost cable is enough. If the cable is too short to prevent the handlebar from rotating, refer to the [Replacing the Cables](#) section to replace the cable with a longer one.
-

3.6 Wheels

Adjusting Rear Wheel Size

Follow the steps below to replace the rear wheel with different size.

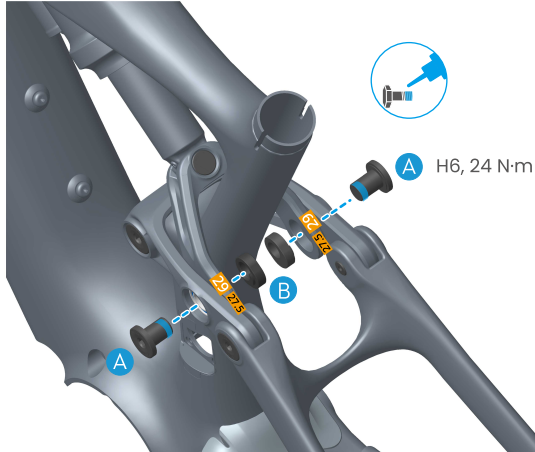

1. Wrap the chain around the smallest cassette cog and then remove the rear wheel and insert the transport spacers into the brake caliper.
2. Remove the shock link bolts (A) and flip chips (B).
3. Align the flip chips (B) with the mark on the yoke and then re-attach them onto the frame. Then insert and tighten the bolts (A) to specified torque.
4. Mount the rear wheel and thru-axle. Ensure that the chain, derailleur, and brakes are correctly positioned, and then tighten the thru-axle to the specified torque.
5. Open the Avinox App and enter the device page, then select the wheel size and tap **Save** to update.

Speed Sensor Ring

The speed sensor ring is mounted on the rear brake rotor. When replacing the rear wheel or rear brake rotor, ensure to detach the speed sensor ring and mount it onto the new rear wheel. Tighten the bolts in the order shown in the illustration.

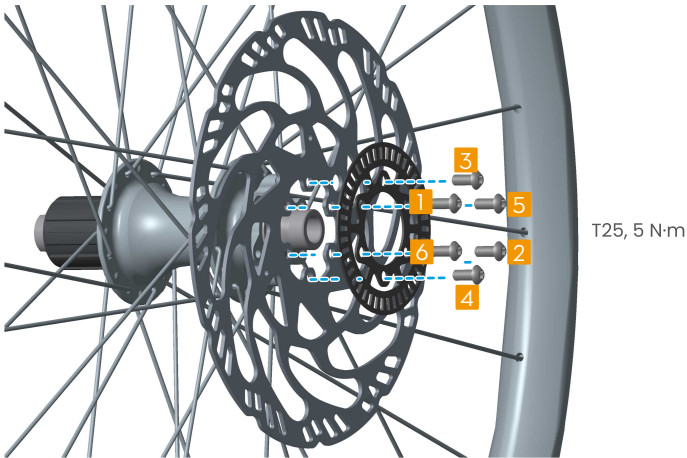

3.7 UDH Hanger

The universal UDH hanger is mounted on the rear dropout of the bike. Follow the steps below to replace.

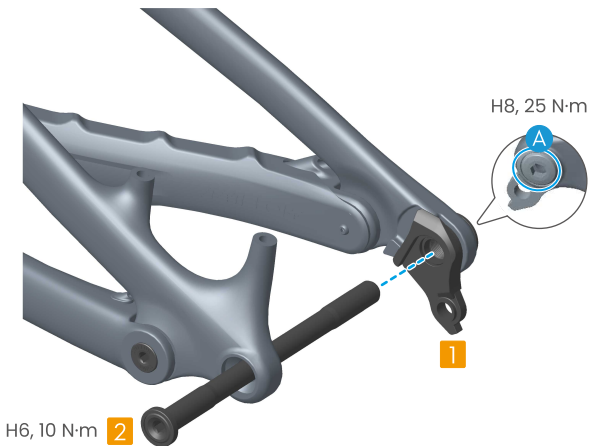

1. Remove the rear wheel. Loosen the UDH hanger bolt (A) clockwise, and then remove the bolt and the UDH hanger.
2. Install the new UDH hanger ① into the frame dropout and rotate it until it completely contacts the stop tab.

3. Install the UDH washer and the bolt (A), then tighten it counter-clockwise to the specified torque. Then mount the rear wheel and thru-axle ②.

- 💡 • Refer to the [Adjusting Rear Wheel Size](#) section to assemble and disassemble the rear wheel.
 - Refer to the manufacturer's manual for more installation instructions of the UDH hanger.
-
- ⚠️ • Regularly check and confirm the UDH hanger is tight and has not moved before and after riding.
 - Do not apply grease to the UDH hanger and UDH hanger bolt.
 - If the rear derailleur of PL Carbon Pro is loose, refer to the manufacturer's manual for installation or ask a professional bike shop for help.
-

3.8 Chainring

- 💡 • Visit the official website to check the supported chainring sizes and mounting interface.
 - A dedicated spider removal and installation tool is required to mount the spider locking ③. Contact the authorized retailer or official customer service to purchase.
-

Follow the steps below to assemble and disassemble the chainring.

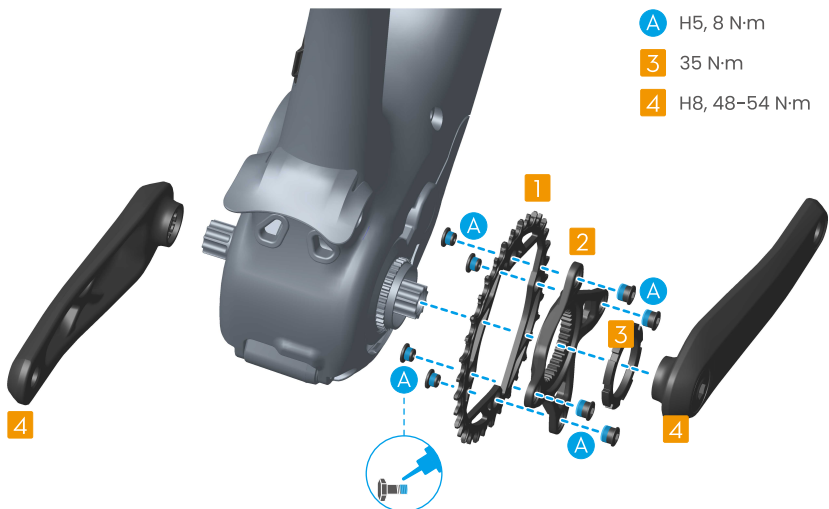

Disassembly

Remove the chain guide and loosen the cranks ④ on both sides, then remove the right crank. Use the spider removal and installation tool to loosen the spider locking ③ counter-clockwise. Remove the chainring ① after removing the chain from the chainring, then remove the left crank.

Assembly

1. Insert the chainring bolts (A) through the chainring ① and the spider ②, and then tighten to specified torque. Then assemble the chainring and spider onto the motor spindle.
2. Mount the locking ③ onto the spider, then use the tool to tighten the locking ③ clockwise to the specified torque.
3. Place the chain onto the chainring and then mount the cranks ④ and tighten to the specified torque.
4. Refer to the Chain Guide section to mount and adjust the chain guide.

Chain Guide

The chain guide and mounting plate have been installed on the frame by default. Follow the steps below to replace and adjust the chain guide.

💡 The chain guide is a genuine component. Please contact the authorized retailer or official customer service to purchase.



1. Mount the chain guide mounting plate ① to the position shown in the illustration. Adjust the plate until the direction of the hole on it is vertical. Then insert the bolt (A) and tighten it to the specified torque.

2. Mount the chain guide ② onto the hole of the mounting plate ①. Rotate the chain guide until the bottom arc of it is concentric with the chainring, and adjust the chain guide up and down according to the size of the chainring. Then insert and tighten the bolt (B) to the specified torque.

3.9 Drive Unit

The drive unit has been installed on the frame. Remove and install the drive unit as shown in the illustration when it is necessary to replace the cables or remove the battery.

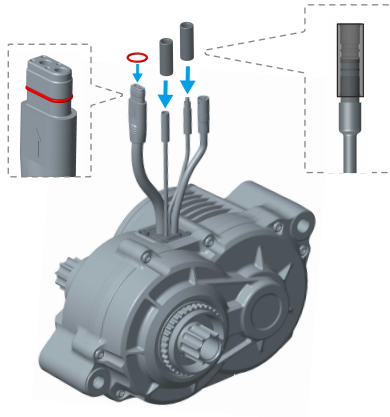

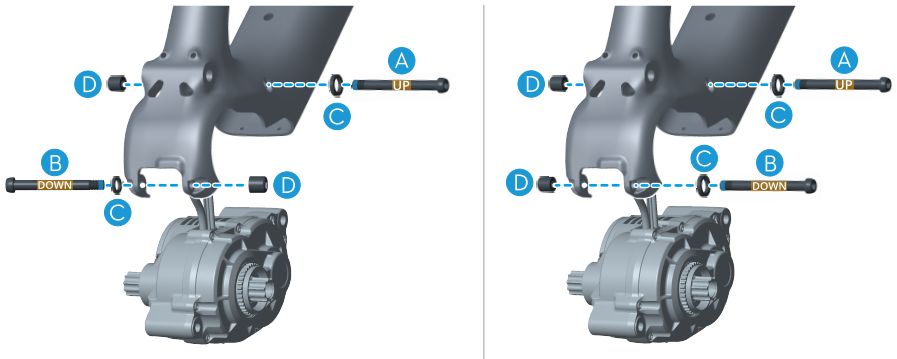

C



	Location	Quantity	Tool	Torque/N·m
A	Motor mounting bolt (up)	1	H6	/
B	Motor mounting bolt (down)	1	H6	/
C	Motor mounting spacers	4	/	/
D	Motor mounting nuts	2	H8	20-22



- The lower motor mounting bolt (B) can be inserted and tightened from either side of the frame to mount the motor.
- The upper and lower motor mounting bolts of different lengths should be distinguished by the mark. The motor cannot be installed if inserting the bolts incorrectly.
- A set of motor mounting spacers (C) includes two serrated spacers. Attach the spacers by aligning the large serrations as shown in the illustration and then install them on the bolt.
- After inserting the bolts, ensure to apply the threadlocker to the exposed threads and then install the motor mounting nuts and tighten.
- Use a wrench to secure the bolts and then rotate the nuts when removing or installing the motor.

Drive Unit Guard

Follow the steps below to replace the drive unit guard if necessary.

1. Loosen the bolts (A) and remove the drive unit guard ①.
2. Mount the new guard on the frame and then insert and tighten the bolts (A) to the specified torque.

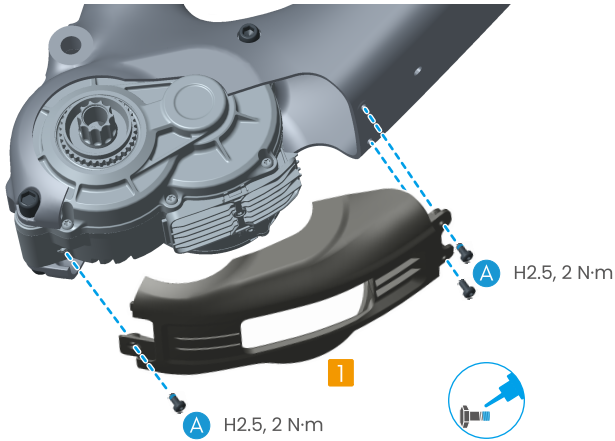

3.10 Control Display

Remove or install the control display as shown in the illustration.

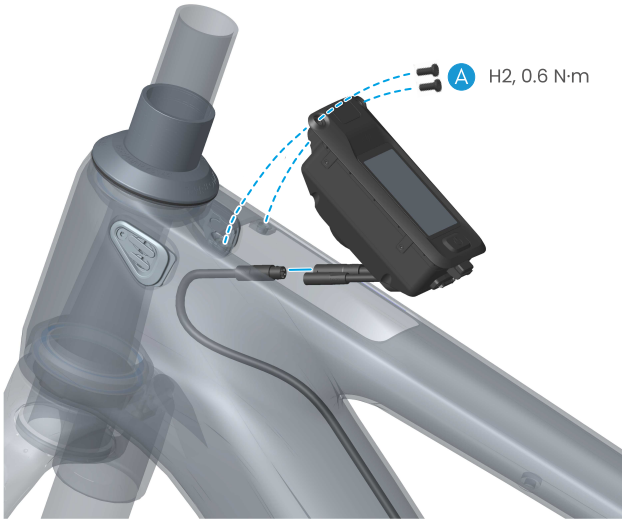

Installing the nano-SIM Card

Prepare a nano-SIM card and install it as shown in the illustration.

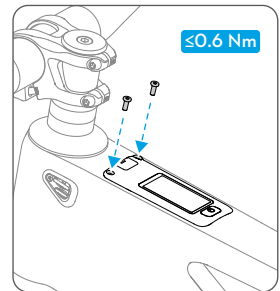
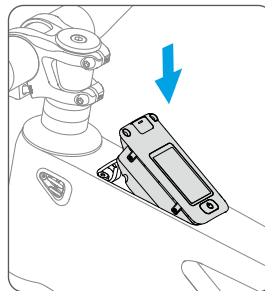
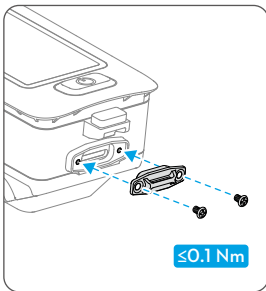
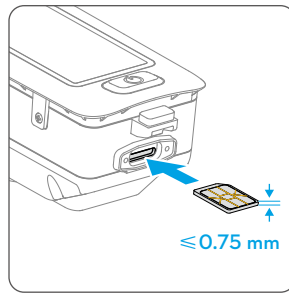
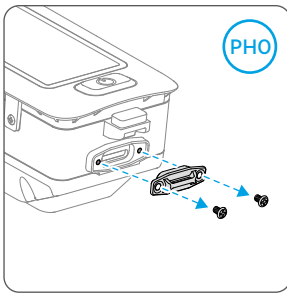
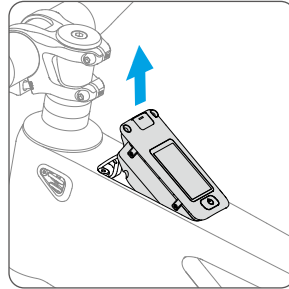
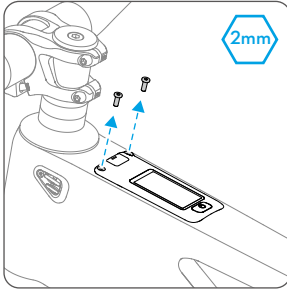

- Make sure to purchase a nano-SIM card which supports 4G network from an official mobile network operator.
- If the SIM card is set with a PIN code, make sure to insert the SIM card into the mobile phone and cancel the PIN code setting. Otherwise, the control display will fail to connect to the internet.
- When removing from the frame, it is recommended to pry up the control display using a tool instead of pulling the Type-C port cover.

3.11 Wireless Controller

The wireless controllers have been installed on the handlebar. Follow the steps below to remove and install the wireless controllers if replacement is needed.

Replacing Battery of Controller

The indicator of the wireless controller will flash red when the battery level is too low. Follow the illustrations to replace the battery.

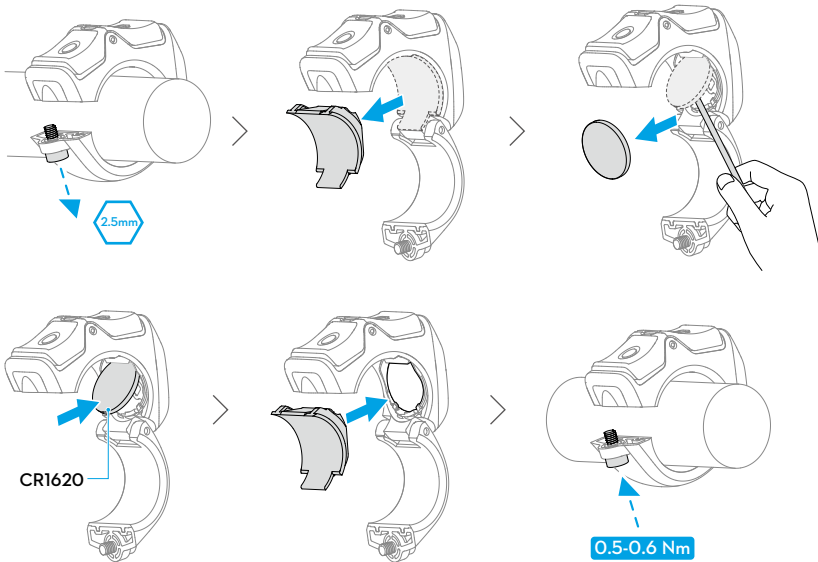

- ⚠ • DO NOT use metal tools to remove the battery as it may cause a short circuit.
- Make sure to clean the installation area and the bolts after multiple disassembly. Otherwise, it may cause abnormal noise during attaching and detaching.

Replacing the Controller

If you need to replace a new wireless controller, it is necessary to pair the new device with the drive system after installation.

When connecting a new wireless controller, press and hold the two buttons on the wireless controller simultaneously until the indicator flashes green and then follow the instructions to connect.

1. Press and hold the power button of the control display to power on, and then power on the accessory.
2. Swipe up the bike screen to enter Settings. Tap **Accessories > Add** and the system will start searching for nearby devices.
3. Tap the device name displayed on the bike screen to start pairing. Follow the on-screen instructions to complete the connection.

3.12 Battery

After removing the drive unit, follow the illustration to remove or install the battery.

-  The 600Wh battery is secured using the bolts (A1) and (A2), while the 800Wh battery is secured using the bolts (A1) and (B). Ensure to tighten the upper bolt first when installing.
 - To install/remove the 800Wh battery, remove the control display first and insert/remove the bolt (B) from the mounting position of the control display. It is recommended to use a flat-head hex key to tighten the bolt (B).
 - Disconnect the power cable first before removing the battery.
-

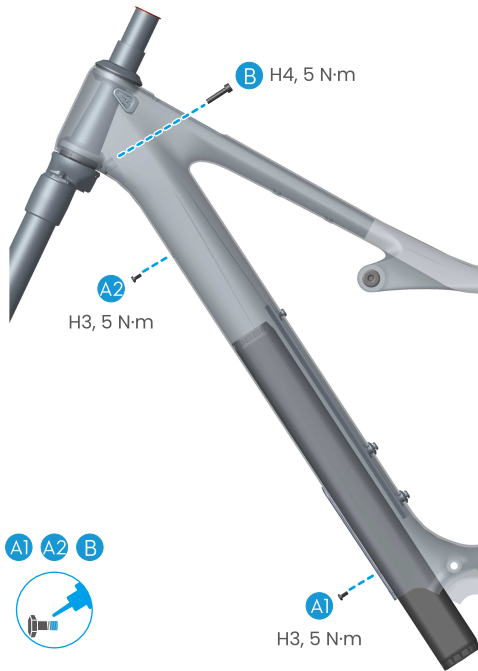

3.13 Speed Sensor

The speed sensor is mounted on the chainstay. If replacement is needed, remove the chainring, drive unit, and rear wheel first. Disconnect the speed sensor from the drive unit and remove the cable from the frame. Then follow the steps below.

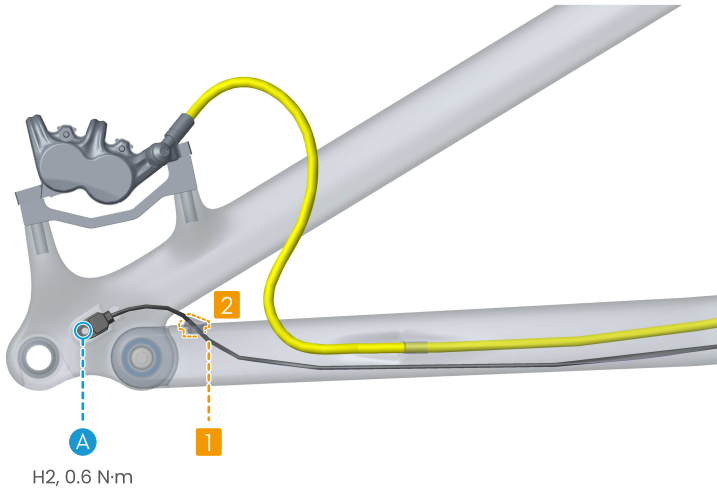

1. Use the cable routing kit to thread the speed sensor cable ① through the chainstay to the bottom bracket.
2. Insert and tighten the bolt (A) to secure the speed sensor and then mount the cable grommet ②.
3. Mount the rear wheel and thru-axle, and then tighten the thru-axle. Connect the cables to the corresponding ports of the drive unit, then install the drive unit and chainring.

3.14 Bike Light and Reflectors

It is necessary to install the bike light and reflectors to ensure the safety while riding at night or in rainy or foggy conditions. The bike light and reflectors should be installed at the designated location. Do not change the installation location.

Bike Light

Install the bike light onto the handlebar and press the button on it to turn on/off the light.

Reflectors

- **Rear reflectors:** The rear reflectors are red and should be installed on the seatpost under the saddle.
- **Wheel reflectors:** The wheel reflectors are yellow or white, which should be mounted on the spoke.

4 Riding Tips

4.1 Before Your First Ride

Make sure to complete all the assembly and adjustments before your first ride.

1. Assemble the bike according to the manuals.
2. Complete the initial setup of the bike:
 - Set up the tires and suspension.
 - It is recommended to adjust the saddle to an appropriate height according to the riding position shown in the illustration. Refer to the [Adjusting the Seatpost](#) section for details or consult an authorized retailers.

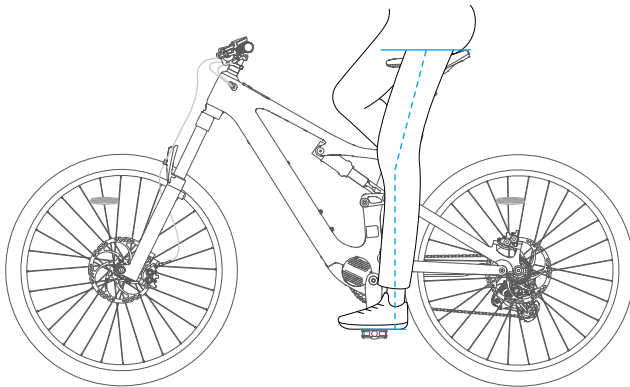

3. Electric bikes differ from the regular bikes. Make sure you fully understand the functionality of the components before riding, such as the brake, shift, seatpost, and drive system.
4. Read the Safety Guidelines before use. Make sure to follow the declared intended use, weight limit, and all the applicable laws and regulations regarding electric bikes.

- ⚠ • Incorrect assembly of the headset and stem may cause damage to the fork steerer tube and thus result in a fall while riding.
- The front brake is on the left-hand side of the handlebar and the rear brake is on the right-hand side by default. Make sure that the lever-to-brake configuration comply with your habits and also the local regulations.

4.2 Before Every Ride

Before riding, make sure to perform a safety check according to the Safety Guidelines. Perform fixes or maintenance in time if any issue is detected. Do not continue to use the bike if it shows any signs of damage. Ask the authorized retailer for a complete inspection.

4.3 Preparation for Riding

Before riding, taking necessary precautions to reduce the risk of injury.

- Always wear a helmet when riding. Follow the helmet manufacturer's instructions for fit and use. Make sure the helmet fits properly and meets the required safety standards.
- Always wear clothing suitable for riding. Loose clothing or accessories may be tangled in the bike.
- Do not wear sandals or ride barefoot. Choose well-fitting shoes that can grip the pedals, and make sure your shoelaces are tied securely.
- It is recommended to wear reflective clothing when riding at night and highlight your feet and legs by wearing reflective accessories.
- Make sure all accessories are secured.

4.4 Drive System

The bike is equipped with Avinox Drive System. Visit the following website for the user manual to learn more about the advanced functions and maintenance information about the drive system:

<https://www.avinox-ebike.com/avinox-system/downloads>

Download Avinox App

It is recommended to connect with Avinox app for a better user experience. Scan the QR code to download the latest version.



- The app will be updated from time to time. The actual interface and functions will depend on the version of the app you are using.
- To check the Android and iOS operating system versions supported by Avinox App, visit <https://www.avinox-ebike.com/avinox-system/downloads>.

Pair and Activate

When powered on for the first time, follow the prompt on the bike screen to complete pairing and activating. Tap **Skip** and you can ride for trial without activation. After the trial distance has run out, follow the steps below to pair and activate before you can continue to use it.

1. Press and hold the power button of the control display to power on.
2. Swipe up on the screen to enter Settings and tap **Pair to App** to view the QR code.
3. Make sure Bluetooth and network are enabled on your mobile device. Open Avinox App, then tap **Pair** and scan the QR code to pair.

Button Features

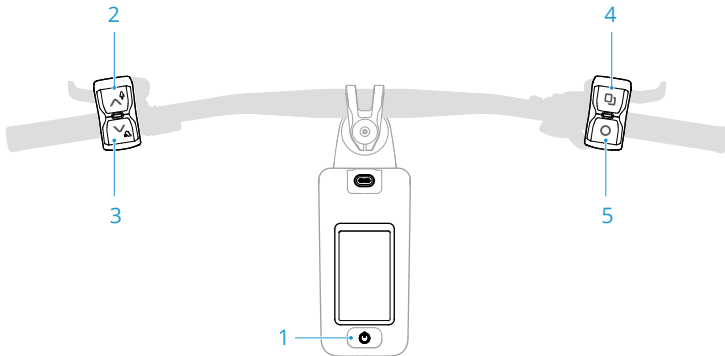

1. Power Button

- Press and hold to power on/off. Press and hold for 20 s to force power off. When powered on for the first time, follow the prompts to select the language and activate the system.
- After powering on, press to switch the assist modes between Off, Auto, Eco, Trail, and Turbo.

2. ^ Assistance Level Increase Button

- Press to switch the assist modes in the order of **Off > Auto > Eco > Trail > Turbo**.

- Press and hold to activate Boost mode and the bike screen will display a countdown. Press the power button or assistance level increase/decrease buttons to exit Boost mode.
3. **▼ Assistance Level Decrease Button**
- Press to switch the assist modes in the order of **Turbo > Trail > Eco > Auto > Off**.
 - Press and hold and then release the button to activate Walk mode. Once activated, press and hold the button to get power assistance to help pushing the bike uphill. Press any other button to exit Walk mode.
4. **🔍 Screen Switch Button (customizable)**
- Press to control the bike screen to slide right.
 - Swipe up on the bike screen to enter Settings, and then you can customize functions for the button in **Customize Controls**.
5. **🏠 Function Button (customizable)**
- Press to control the bike screen to slide left. When the bike screen is on Settings page, press to return to previous page.
 - Swipe up on the bike screen to enter Settings, and then you can customize functions for the button in **Customize Controls**.

Assist Mode

Standard Mode

The four standard modes offer varying level of assistance to handle different riding scenarios.

Auto: This mode automatically adjusts assistance based on different riding situations, providing a moderate level of assistance to enhance the range.

Eco: With gradual start-up acceleration and lower assistance, this mode conserves battery energy and is suitable for long-distance flat terrain riding.

Trail: This mode provides moderate start-up acceleration and stronger assistance and is suitable for cross-country technical route.

Turbo: This mode provides maximum assistance and is suitable for steep slopes.

Boost Mode

In addition to the standard assist modes, the drive system also support the Boost mode with extra assistance for a short duration, which can help users riding with greater

drive torque and power. This mode is suitable for challenging riding scenarios such as overcoming obstacles and climbing hills.

Press and hold \wedge to activate Boost mode. During the period, the assistance will shut off when you stop pedaling. To exit Boost mode, press the power button or assistance level increase/decrease buttons.

Walk Mode

Press and hold \vee to activate Walk mode, then press and hold the button to get power assistance when pushing the bike or starting upon an incline. It also supports auto hold to prevent rollback on slopes.

The assistance will shut off automatically when stop pressing \vee or the speed exceeds 6 km/h.

Stationary Gear Shifting

Stationary gear shifting is supported when using Walk mode. After activating Walk mode, press the shift lever and lift the rear wheel, then press \vee twice to shift gears quickly.





- Only use Walk mode when pushing the bike. Using in inappropriate situations may cause accidents and personal injury.
 - Ensure to keep your body away from the rotating crank and pedals to avoid injury when using Walk mode to assist pushing the bike and gear shifting.
-

5 Maintenance

5.1 Bike Maintenance



It is recommended to have the authorized retailer regularly perform inspection and maintenance on your bike to ensure its longevity and riding safety.

-
-  Fixing and maintaining the bike requires professional skills and specialty tools. For the safety, ask the authorized retailer or profession bike shop to perform the maintenance and repairs not specifically described in this manual.
 - The lifespan of the components depends on riding conditions and frequency. Regularly have the authorized retailer inspect the bike and components for wear.

-
-  Do not attempt any maintenance or repairs until you fully understand the correct operations. Incorrect operations may cause damage to the bike and thus result in accidents.
 - Do not continue to use the bike if it shows any signs of damage. Ask the authorized retailer for a complete inspection.
 - Always power off the system when performing inspection and maintenance on the bike.
 - When placing the bike in a repair stand, do not clamp the stand to the frame, as this may cause damage to the frame and result in accidents during riding.
-

Cleaning

Regularly cleaning your bike can reduce the wear on surface and extend the lifespan of the components.

-
-  Use a damp cloth with a neutral detergent to clean your bike. Do not use harsh chemicals or alcohol.
 - Refer to the manufacturer's instructions for details on cleaning the transmission and derailleur.
-
-  Make sure to close the covers of the ports before cleaning.
 - Do not use a high pressure water spray to clean the electrical components, bearings and seals.
-

Lubrication

Once you have cleaned your bike, lubricate the transmission and moving parts according to the manufacturer's instructions if necessary. Consult the authorized retailer about the appropriate lubricants and the recommended lubrication frequency for your bike.



- Regularly lubricate the thru-axle. The maintenance frequency depends on how often the wheels are detached.



- Do not apply the lubricants to the brakes, pedals, and rims.
 - Do not rotate the chainring backward when cleaning and lubricating the chain. Otherwise, the drive unit and battery may be damaged.
-

5.2 Regular Inspection

The mechanical components on the bike have limited service life. Continuing use beyond the lifespan may cause sudden damage. Regularly inspect your bike to avoid the accidents caused by the components damage.

Professional tools and skills are not required for the inspection and maintenance of certain components, which can be performed by yourself. For other components, the service must be performed by the authorized retailer or professional bike shop according to the manufacturer's instructions.



- Refer to the manufacturer's instructions to learn more about the service of the components.
 - Regularly maintain the rear shock and fork according to the manufacturer's instructions.
 - The maintenance periods in this manual are for reference only. Please inspect your bike in time according to the riding conditions and frequency.
 - Make sure to perform a complete inspection and maintenance to your bike after riding for a long-distance or riding in adverse conditions and in the rain.
-

First Inspection

It is recommended to have the authorized retailer inspect your new bike after using for a while.

Every Month

- Check whether the handlebar grips are still secure.
- Check whether the transmission is working normally. Use professional tools or ask a bike shop to check if the chain is stretched.

- Check the speed sensor and speed sensor of the accumulation of dirt or foreign matter.
- Check the brake rotors and pads for wear. Replace the brake components if necessary.
- Check the tires for damage or any worn area.
- Check the spoke for being loose or damage.
- Check whether the cranks are loose. If so, tighten them according to the specified torque.
- Inspect the welding and connection points of the frame for cracks, deformations, or rust.

Every Six Months

- Check the frame for any cracks or other signs of damage.
- Check and lubricate the hub, headset, and other components that are subject to friction.
- Clean and tighten the cranks, chainring, and cassette.
- Check the frame for any internal cracks.

Every Year

- Inspect and service the headset.
- Regularly replace the brake fluid according to the manufacturer's instruction to ensure the brake performance.

5.3 Replacing Wearable Components

Replace the components if there are any cracks, scratches, wear, or abnormal noise. Consult the authorized retailer or official customer service if you have any doubt about the degree of wear on the components.

-
- 💡 • Refer to the [Assembly](#) section to replace the genuine components.
 - It may be necessary to remove the drive unit, battery, and cable guide when replacing the components. If you cannot operate by yourself, it is recommended to have the authorized retailer or professional bike shop perform the replacement to prevent damage from improper handling.
 - Contact the authorized retailer or official customer service to purchase the genuine components if replacement is needed.
-

Components	When to Replace
Bearings	When the bearings are not turning smoothly or have excessive play.
Spacers	When the surface shows worn.
Chain guide and chain guide mounting plate	When there have deformation or damage.
Motor Cover	When there have any cracks or damage.
Cables	When there have fracture, wear, rust, or kinks.
Tires	When there have worn areas or cracks.
Chain	When the chain is broken or stretched, or the shifting performance declines after riding a certain distance.
Handlebar grips	When the grips are damaged.
Brake	When the brake rotors and pads are worn and become thinner.
Down tube/Chain-stay protectors	When the protector is damaged and can no longer protect the frame.
UDH Hanger	When there have deformation or damage.

Bearing and Spacer Specifications

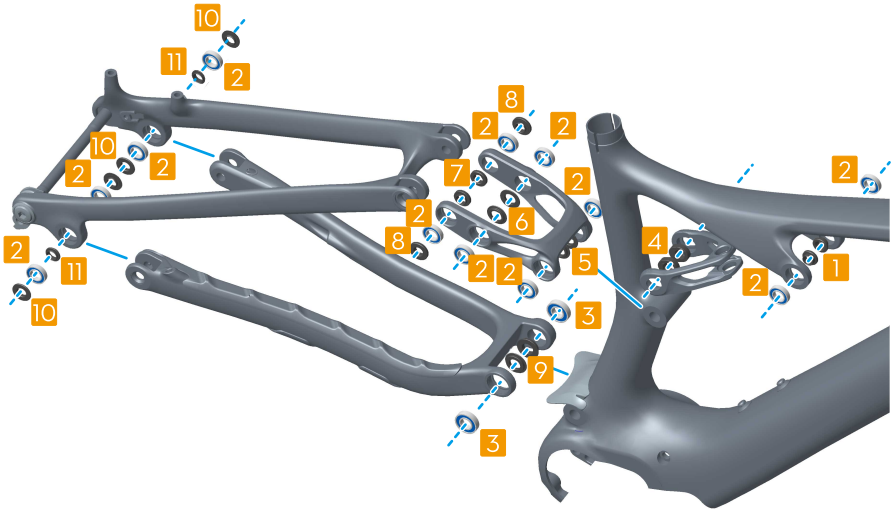

Location	Quantity	Dimension (ID×OD×W) /mm
1 Shock mounting spacers	2	10×16.5×6.9

	Location	Quantity	Dimension (ID×OD×W) /mm
2	6801 bearings	12	/
3	6901 bearings	2	/
4	Flip chips	2	M12×21.8×7.6
5	Seat tube pivot spacers	2	12×21.5×3.4
6	Yoke at shock link spacers	2	12×22×2.9
7	Seatstay pivot spacers (φ18)	2	10×18×5.4
8	Seatstay pivot spacers (φ20)	2	10×20.5×5.4
9	Main pivot spacers	2	12.2×24×4.9 (left) 12.2×24×3.4 (right)
10	Swingarm pivot outer spacers	4	10.1×20.5×3.7
11	Swingarm pivot center spacers	2	10.1×16×5.5

Replacing the Cables

If replacement is needed, it is necessary to loosen the cable guide bolts and then follow the steps to replace different types of cables.

Cable Guide

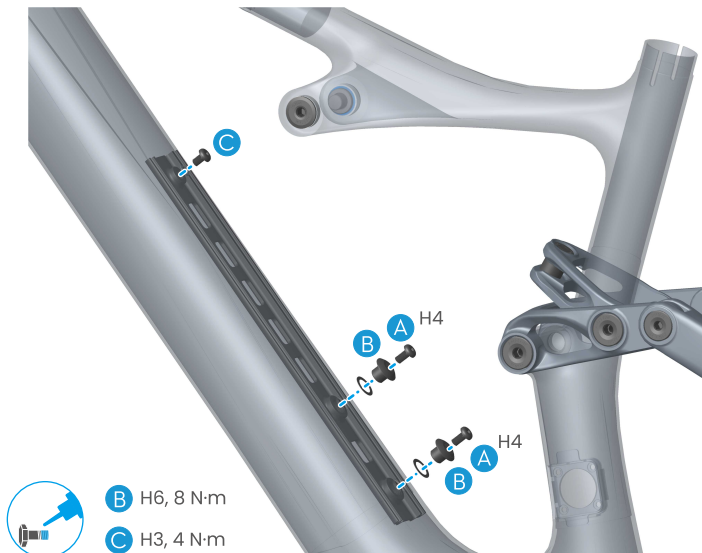

-  Before loosen the cable guide bolts (B), it is necessary to remove the water bottle cage bolts (A) first. Tighten the bolts (A) to the required torque according to the specifications of the water bottle cage when assembling.
 - Follow the instructions to loosen the cable guide bolts. The recommended number of turns for loosening is based on the premise that the bolts are tightened to the specified torque. Excessive loosening may cause the cable guide to become loose. Refer to the [Cable Routing](#) section to place the cables into the corresponding position before re-tightening the cable guide.
-

Rear Brake Cable

After removing the drive unit, remove the rear brake cable from the frame. Route the new brake cable through the corresponding position of the cable guide and the outlet of the head tube. Ensure to reserve enough length and then install the cable. Refer to the manufacturer's manual to learn the details about installing the cables.

Rear Derailleur Cable

After removing the drive unit and loosening the cable guide bolts by 2 turns, remove the rear derailleur cable from the frame. Route the new cable through the corresponding position of the cable guide and the outlet of the head tube. Ensure to reserve enough length and then install the cable. Refer to the manufacturer's manual to learn the details about installing the cables.

Seatpost Cable

1. Remove the drive unit and then loosen the cable guide bolts by 2 turns.
2. Loosen the pinch bolt (A) on the seatpost lever and remove the cable from the lever.* Refer to the [Adjusting the Seatpost](#) section to loosen the seatpost clamp bolt, then remove the seatpost and the cable from the frame.

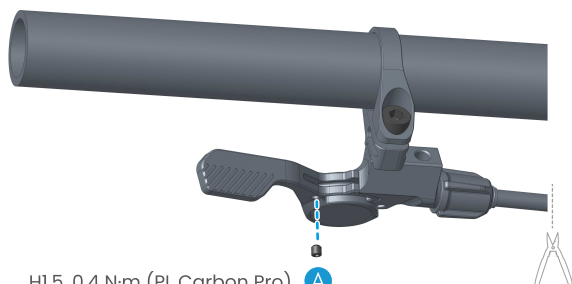

H1.5, 0.4 N·m (PL Carbon Pro) **A**

H1.5, 0.2 N·m (PL Carbon)

* For PL Carbon, the seatpost cable must be cut to remove.

3. Route the new cable through the corresponding position of the cable guide and the outlet of the head tube. Ensure to reserve enough length. Install the seatpost cable to the seatpost and the lever according to the manufacturer's instruction.
4. Tighten the cable guide bolts and the pinch bolt (A) to the specified torque.

Drive Unit to Display Cable

Remove the drive unit, battery, and control display first and detach the drive unit to display cable from the drive unit and control display. Then follow the steps below.

1. Remove the cable guide bolts and the cable guide, then remove the drive unit to display cable from the frame.
2. Route the new cable through the down tube from the mounting position of control display. Secure the upper end of the cable to the top tube.
3. Place the cables into the corresponding positions of the cable guide, then push the cable guide into the down tube and pre-tighten the bolts. Pull all the cables to ensure there are no displacements and then tighten the bolts to the specified torque.
4. Reinstall the battery, control display, and drive unit.

5.4 Link Maintenance

It is necessary to maintain the connection between the yoke and rear shock when there are abnormal noises during riding. Follow the steps below to perform the maintenance.

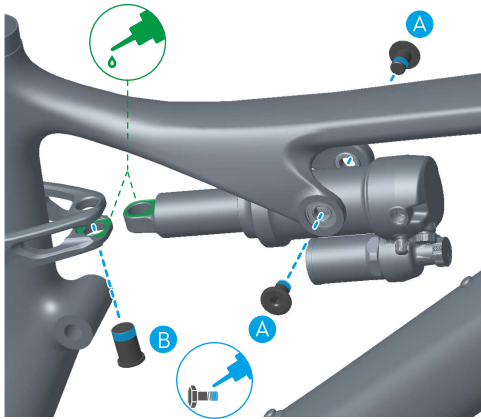

1. Remove the forward shock mounting bolts (A) and then the rear shock mounting bolt (B).
2. Remove the rear shock, then clean and lubricate the contact surfaces between the shock and yoke. Ensure not to apply the grease to the bolt mounting holes.
3. Apply the threadlocker to the thread of the bolts and mount the rear shock. Insert and tighten the rear shock mounting bolt to the specified torque, then insert and tighten the forward mounting bolts.

5.5 Battery Maintenance

- 💡 • Charge the battery at a temperature range of 0° to 40° C (32° to 104° F). Charging at the ideal temperature range can prolong battery life.
 - The battery should be stored in a cool and dry environment without direct sunlight at a temperature from 0° to 40° C (32° to 104° F).
 - Regularly check the battery level and battery cycle counts. Battery capacity may be affected after using for 500 cycles, which will not impact riding.
 - When the battery level is less than 10%, charge promptly as it will affect battery life.
 - Battery life may be reduced if not used for an extended period. Fully charge and discharge the battery at least once every three months to ensure the performance of the battery.
-
- ⚠️ • DO NOT continue to use if the charger port or cable shows signs of wear or other damage.

- Disconnect the battery from the charging device when it is fully charged. DO NOT overcharge the battery. Otherwise, the battery cells may be damaged.
 - The battery life may be reduced if it is charged at a high temperature. After each ride, allow the battery to cool down to approximately room temperature before charging. Charging the battery at a temperature of 0° to 40° C (32° to 104° F) can extend the battery life significantly.
 - Remove the battery from the frame when stored for an extended period and keep it out of the reach of children.
 - If the battery needs to be stored for a long time, it is recommended to discharge the battery to 30%. Storing with a high battery level will shorten the battery life, and storing with a low battery level may lead to over-discharge.
 - Before transportation, discharge the battery to below 30%. For long-distance transportation or battery shipping, use a dedicated carrying box to prevent damage. DO NOT transport a damaged battery.
-

5.6 Storage and Transportation

Storage

-  • Make sure to power off the drive system when storing the bike for an extended period.
 - It is recommended to clean and service the bike before storing for an extended period.
 - Store the bike in a dry, cool, and well-ventilated environment.
-

Transportation

-  • Make sure to inform yourself of all applicable laws and legal regulations regarding electric bikes in the destination country or region if you need to transport the bike.
- Be aware that the electric bike is heavier than a regular bike. Be careful when carrying or lifting it.
- Transporting the battery may be subject to restrictions and require special packaging. Make sure to inform yourself of all applicable local laws and legal regulations or consult the authorized retailer or official customer service for more information.

- Make sure to remove all movable and loose parts before transporting the bike. Make sure to protect the ports to prevent the ingress of water spray and dust when transporting the battery separately.
-



AMFLOW is a trademark of AMFLOW.
Copyright © 2025 AMFLOW All rights reserved.